

FLYING YOUR PTERODACTYL

Any contest boost glider requires a lot of room. Find a really big field. Whether you use a parasite or a pop-pod, make sure your glider separates easily and clearly from the booster. Don't launch in a high wind or you are guaranteed never to see your glider again . . . and somebody in the next county will get an unexpected addition to his airplane collection. It's smart in any case to write your name and address on the glider so it can be returned if it strays a long way from home.

ENGINES:

Igniters and complete engine installation instructions are included in "Engine Operating Instructions" which accompany all Enerjet engines.

Short delay or mid-range delay engines are best, due to the high drag of the Pterodactyl at liftoff.

The following engines are recommended when flying the Pterodactyl on a large, long booster such as the Enerjet Aero-Dart.

- E24-4 — Test flights & Eagle Class Competition
- F52-5 } — Condor Class Competition
- F67-6 }

MODEL ROCKETEER'S SAFETY CODE

CONSTRUCTION

My model rockets will be made of only lightweight materials such as paper, wood, plastic, and thin metallic foils, with the exception of payloads and engine holders made of wirelike material.

ENGINES

I will use only pre-loaded factory made model rocket engines in the manner recommended by the manufacturer. I will not change in any way nor attempt to reload these engines.

RECOVERY

I will always use a recovery system in my model rockets that will return them safely to the ground so that they may be flown again.

WEIGHT LIMITS

My model rocket will weigh no more than 453 grams (16 oz.) at liftoff, and the engines will contain no more than 113 (4 oz.) of propellant, as prescribed by Federal Regulations.

STABILITY

I will check the stability of my model rockets before their first flight except when launching models of already proven stability.

LAUNCHING SYSTEM

The system I use to launch my rockets will be remotely controlled and electrically operated, and will contain a switch that will return to "off" when released. I will remain at least 10 feet away from any rocket that is being launched.

LAUNCH SAFETY

I will not let anyone approach a model rocket on a launcher until I have made sure that either the safety interlock key has been removed or the battery has been disconnected from my launcher.

LAUNCH AREA

My model rockets will always be launched from a cleared area, free of any easy-to-burn materials, and I will only use non-flammable recovery wadding in my rockets.

BLAST DEFLECTOR

My launcher will have a blast deflector device to prevent the engine exhaust from hitting the ground directly.

LAUNCH ROD

To prevent accidental eye injury I will always place the launcher so the end of the rod is above eye level or cap the end of the rod with my hand when approaching it. I will never place my head or body over the launching rod. When my launcher is not in use I will always store it so that the launch rod is not in an upright position.

POWER LINES

I will never attempt to recover my rocket from a power line or other dangerous places.

LAUNCH TARGETS AND ANGLE

I will not launch rockets so their flight path will carry them against targets on the ground, and will never use an explosive warhead nor a payload that is intended to be flammable. My launching device will always be pointed within 30 degrees of vertical.

PRE-LAUNCH TEST

When conducting research activities with unproven designs or methods, I will, when possible, determine their reliability through pre-launch tests. I will conduct launchings of unproven designs in complete isolation from persons not participating in the actual launching.

FLYING CONDITIONS

I will not launch my model rocket in high winds, near buildings, power lines, tall trees, low flying aircraft or under any conditions which might be dangerous to people or property.

Enerjet

A SUBSIDIARY OF CENTURI ENGINEERING CO.

PTERODACTYL

(TER/E/DAC/TIL) THE ORIGINAL FLYING DINOSAUR

EAGLE/CONDOR CLASS BOOST GLIDER

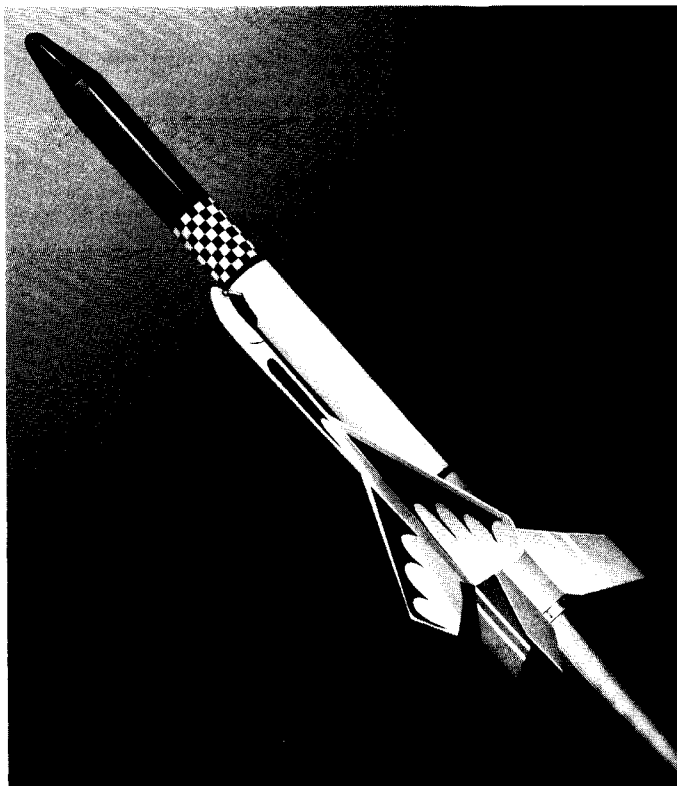

BOOSTER NOT INCLUDED

Length	15.5"
Body Diameter	Span - 9"
Net Weight	1.6 oz.

Recommended Engines (when boosted by Aero-Dart).

E24-4 F52-5 F67-6

Enerjet

Catalog No. KE-6

PTERODACTYL

The Enerjet PTERODACTYL is specifically designed as a glide duration vehicle for use with Enerjet powered rockets. Engineered to withstand high liftoff acceleration, the Pterodactyl's aerodynamic shape is the result of extended testing and research. The Pterodactyl obtains its lift from the canard being at a slight incidence to the wings. Materials are included in this kit to allow for pop-pod mounting or tack-on mounting. The choice of launch vehicles is up to you, but we recommend using the tack-on system with a large Aero-Dart type of rocket for first test flights.

Close attention to instructions and a craftsman-like attitude will produce a glider worthy of Eagle and Condor class boost glide flights.

The Pterodactyl is designed to be flown either as a "parasite" glider or as a front engine "pop-pod" glider.

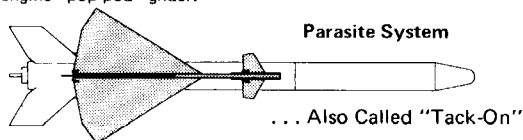

With a "Parasite" system, the glider hitches a ride on a considerably larger rocket. Usually the booster is capable of flying alone with the glider. The main advantage of the parasite system is reliability. The performance of the big booster is known and the glider, while adding drag, doesn't usually change the flight characteristics very much. The main disadvantage of this method is that the booster vehicle adds drag and weight to the system without contributing to the glide time.

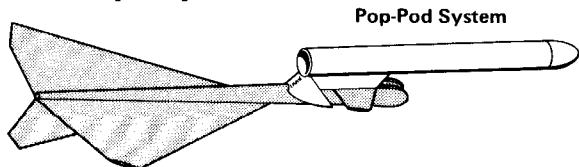

With a front engine "pop-pod" system, the glider is carried up by a very light, compact pod. Rid of the weight and drag of a parasite type booster, the glider boosts higher and faster. The glider is subject to greater stress with a pop-pod than as a parasite and is more prone to looping or flying apart. On the other hand an experienced modeler can beat a parasite glider with a pop-pod. The engine pod "pops" off when it ejects its parachute.

The Pterodactyl obtains gliding ability because the canard is at a slight incidence to the wings. This incidence angle is pre-cut in the body strip.

TOOLS: In addition to the parts supplied, you will need the following tools to assemble and finish this kit. **DO NOT** use model airplane glue for building flying model rockets.

ASSEMBLY INSTRUCTIONS

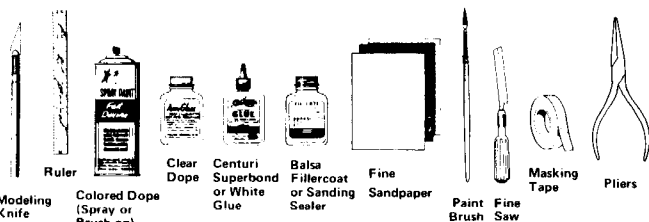

1 Because the Pterodactyl is considerably different from other model rocket kits, we strongly urge you to read all these instructions thru before starting assembly.

Set the "Plan Sheet" to one side near you for reference while studying and assembling the kit. The Plan Sheet views are drawn full size.

2 Each of the printed balsa sheets should be cut into two sections as shown below. This will simplify cutting the individual pieces, and avoid accidental splitting. As you proceed with building later on, cut out the individual pieces as you need them. The numbers printed on the sheets aid in identification.

TWO WING & MOUNT SHEETS

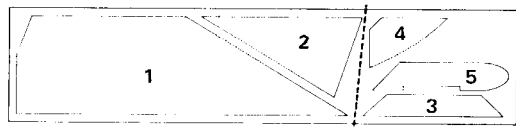

TAIL & CANARD SHEET

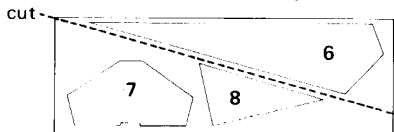

1. Main Wing Section
2. Wing Fillet
3. Mount Plate
4. Mount Hook
5. Nose Block
6. Rudder
7. Canard
8. Dihedral Guide

The numbers shown refer to numbers printed on the balsa sheets.

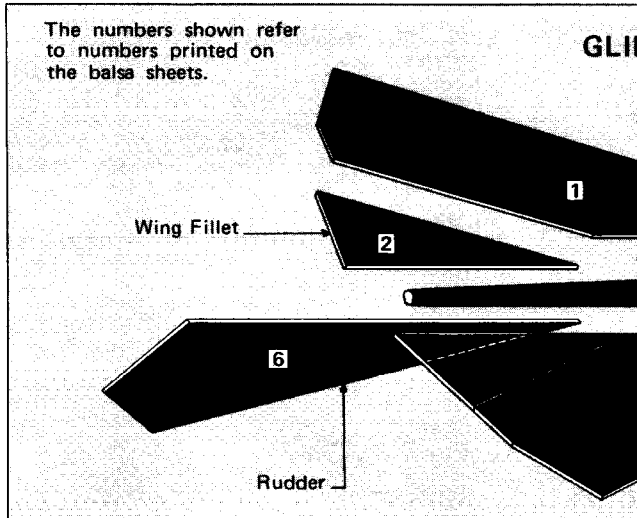

3 Cut out the main wings (#1) and wing fillets (#2). Test fit each fillet against its main wing, being sure to align the grain direction. If necessary, sand joint edges for neat fit. Glue edges together and let dry on flat surface.

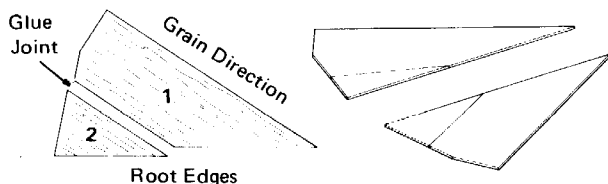

4 The trim weight compartment may be cut with a saw or it may be carefully whittled with a knife. At any rate, holding the piece in a vise is very helpful. Cut the trim weight compartment piece out, but don't do any further shaping.

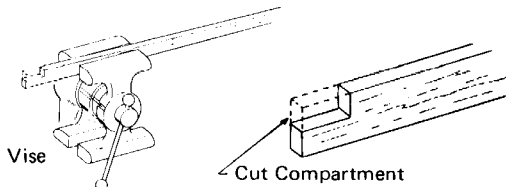

5 Cut the two nose blocks out carefully and glue firmly onto both sides of the body strip, **MAKING TOP EDGES FLUSH**. After glue has set, trim notch for canard, round the tip of the body strip, and trim the underside of the nose blocks.

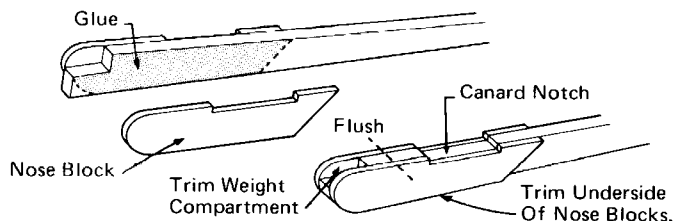

6 By now the wings should be dry enough to handle. Run each edge over fine sandpaper to insure straight edges. Cut out the balsa dihedral guide (#8) and use it as shown to obtain the proper angle between wings, sand a slight bevel on each wings root edge and glue the wings together. Allow to dry on a flat surface, propping one wing with the dihedral guide.

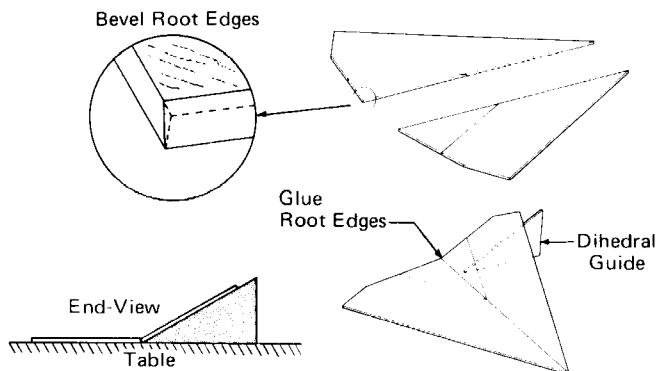

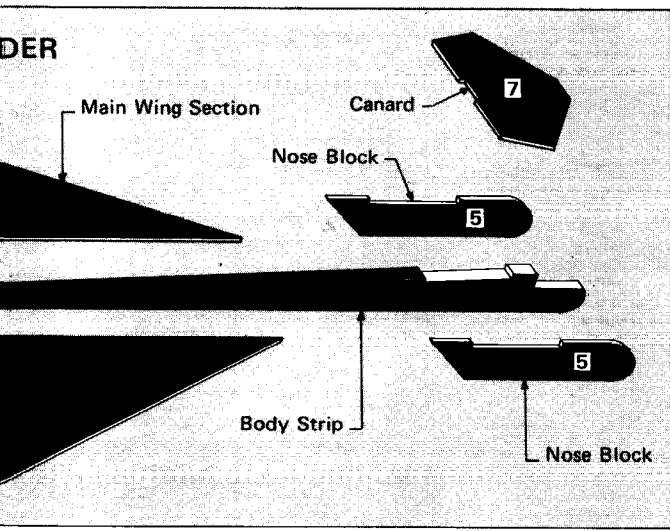

7 Now is a good time to shape the body strip. Study the cross section views on the Plan Sheet. The top edge should be rounded, starting just behind the nose block. The bottom edge should be carved to a "V" shape (for accepting the wings) starting 9" from the rear. DO NOT sand or shape the nose block area.

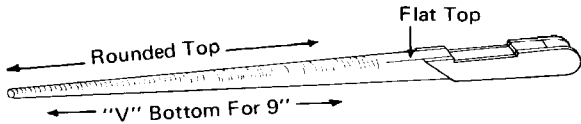

8 Cut out the canard (#7) and glue it into its notch. Apply a glue bead around the joint edges and smooth into neat fillets with your finger. Use fine sandpaper to gently round the front of the glider as shown in the nose cross section diagram on the plan sheet.

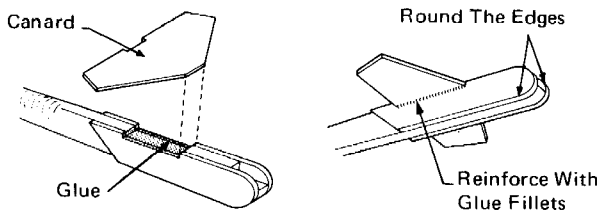

9 Run a bead of glue along the wing's centerline and glue the body strip in place. Check alignment and fasten the two assemblies temporarily with tape or pins. Lay the joined assemblies upside down on a flat surface, and prop the canard into a level position with scrap balsa.

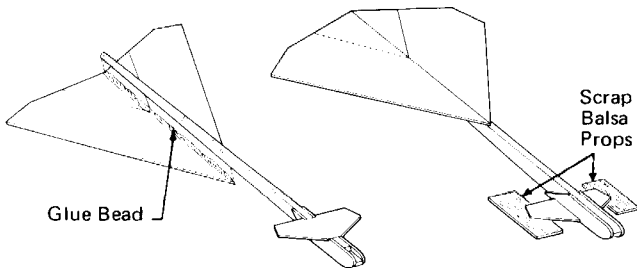

10 Cut out the rudder (#6). Identify its root edge from the drawing below and glue it onto the upside down glider. Again, use tape or pins to hold it in place while glue dries. Check the end view one more time for neat, symmetrical parts alignment.

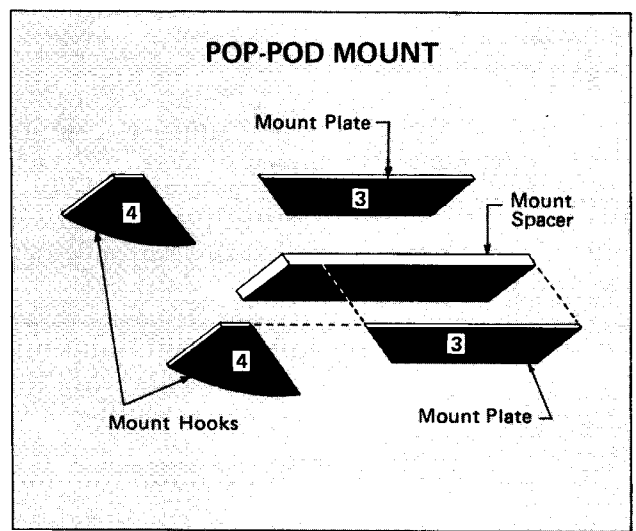
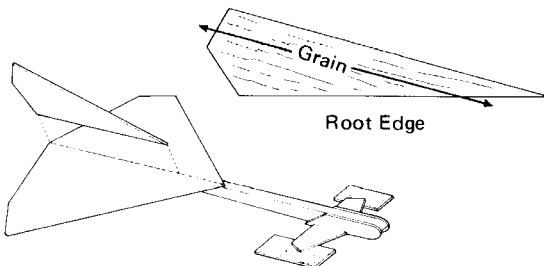

11 NOTE: While the glider's glue joints are drying, the mounts may be assembled. We suggest you build both types of mounts. It is easy to do both at once, and you may decide to use both of them later on. When you are about halfway through the mount assembly, return to the glider to apply one more glue fillet to all joints.

12 ASSEMBLING THE POD MOUNT

A. Cut out a mount hook (#4) and a mount plate (#3). Glue these together on a flat surface, referring also to the Plan Sheet. Repeat with the other hook and plate.

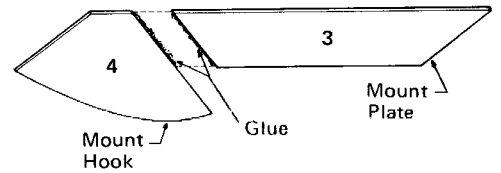

B. Glue each mount/hook assembly onto the basswood mount spacer. Note that the basswood protrudes up about 1/8" from the mount/hook. This is intentional.

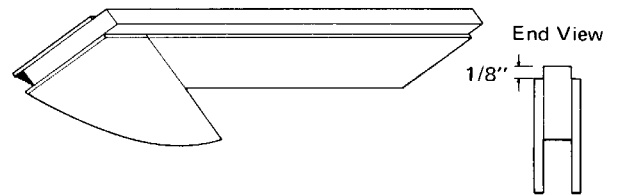

C. When you later fasten the mount to a pop-pod (of your own design) you have a choice of two methods.

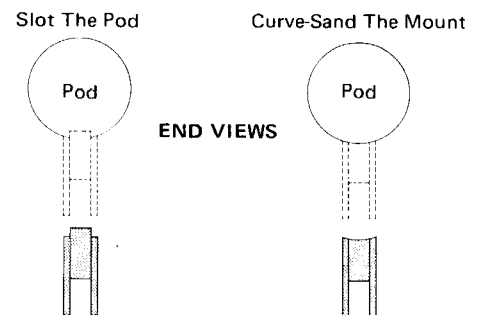

D. Position the mount on the glider. Round all exposed edges to obtain an aerodynamic and pleasing appearance.

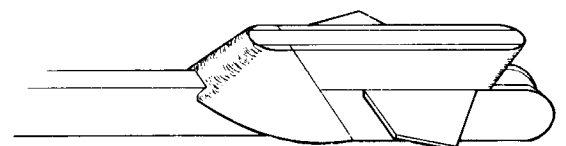

13 Use the wire supplied in the kit to make the wire mounts for "parasite" flying. Cut two 5" lengths and bend each neatly to the dimensions shown. Save the "scrap" wire for a later step.

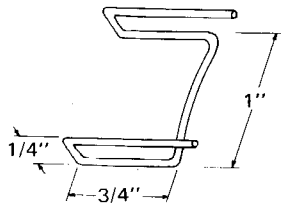

14 Position and test-fit these wire mounts on a large Aero-Dart type of rocket. Arrange hooks and glider until you have arranged the glider comfortably as far to the rear of the rocket as possible. Fasten the wire hooks onto the rocket with tape. The glider should be able to slide forward, disengaging itself easily from the hooks.

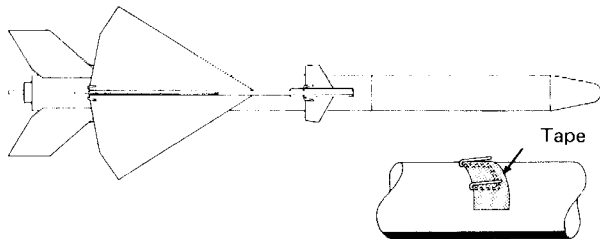

15 All exposed edges need to be sanded to a tapered cross section. DO NOT AIRFOIL THE WINGS OR CANARD! Lightly sand wing and rudder surfaces to remove any fuzziness. If you have not yet reinforced all glue joints with a glue fillet, do so now.

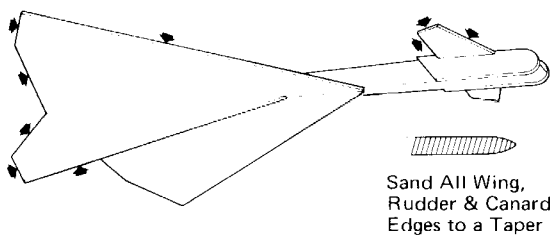

16 The wings must be strengthened with Silkspan tissue, to withstand lift off acceleration. Work on one surface at a time.

A. Carefully cut the tissue into 6 pieces. Each is slightly larger than the surface it will be used on.

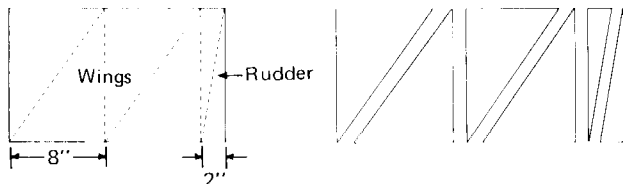

B. Brush a generous quantity of clear dope onto a wing surface. Apply the tissue quickly before dope dries, and rub it firmly onto wing.

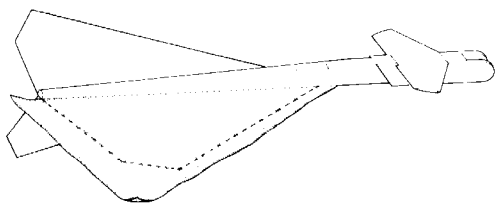

- C. Trim away excess paper and repeat with the other wing and rudder surface.
- D. Apply another coat of clear dope to seal the tissue surface.
- E. Sand all exposed wood surfaces with a very fine sandpaper.
- F. Apply one coat of sanding sealer or filler coat to wood and sand. No more than two coats should be used as it will increase weight and decrease performance.

17 The Pterodactyl should be painted in high visibility colors due to its high-altitude and long-distance capabilities. The underside is the view you will see from the ground, so choose either a dark color (such as black or red), or a bright one (such as orange).

We recommend using a spray dope for light, even covering.

18 Apply the decals according to instructions printed on the decal backing paper. They may be applied to whatever surface you think they look best on.

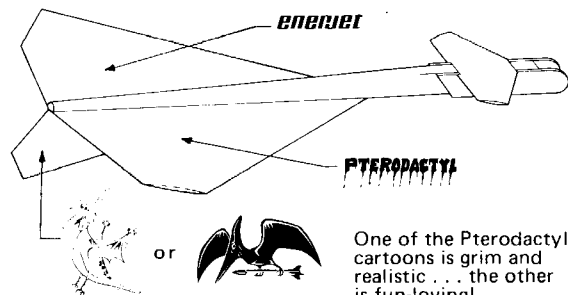

TRIMMING YOUR GLIDER:

How well your glider flies depends largely on how well you balance (or trim) it before launch. You trim by hand launching your glider, watching it carefully, and correcting for excess turning, diving or stalling.

- A. Tamp a little clay into the trim weight compartment.
- B. Find a clear area, (hopefully with soft grass) to hand launch your glider. Throw your glider lightly into the wind. If the glider stalls, add a little clay. If it dives, remove a little clay.

STALLS: Add Clay



DIVES: Remove Clay

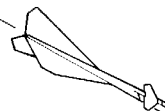

- C. With practice you can launch off the wind so it turns and glides with the wind on a long glide.
- D. More accurate ground testing may be done with the sling-launch method. Bend a hook from the scrap 2" piece of wire, insert into nose section and hold in place with tape. A sling is easily made from a small stake (driven into ground), 20 feet of string, and 4 or 5 feet of shock cord (or rubber bands looped together). Tie a loop in the string end so that it easily slips off the hook. Launch into wind at slight upward angle, starting with very little tension for first flights. Correct for trim and increases tension for longer flights.

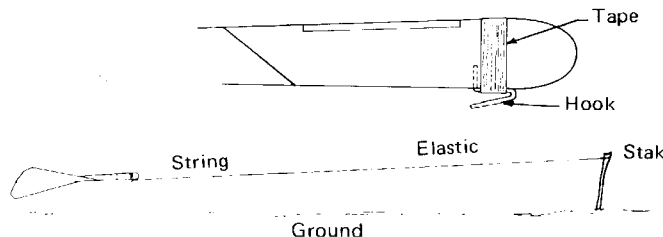

- E. The Pterodactyl should circle slightly while gliding. If it glides perfectly straight, it can easily glide out of sight. If the Pterodactyl turns too much to the left, add a little clay weight to the opposite wing tip, and visa-versa. Avoid sharp spiraling turns as this drastically decreases performance.
- F. You may want to boost your glider parasite style with a small engine to test its glide before powering it with an enerjet. Many fine gliders have done poorly in contests because the contestant didn't take the trouble to thoroughly glide test it first. Your Pterodactyl is a rugged design. You can do a lot of hand launching without hurting it. And it's fun!
- G. Test fit the glider onto the balsa pod mount. The glider should disengage easily. If necessary, sand the inside surfaces of balsa mount hooks slightly. Do not sand too much, or glider will wobble. If you make a Pop-Pod, be sure the fully prepped model passes the stability swing test.

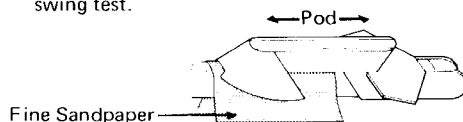

(cont.)

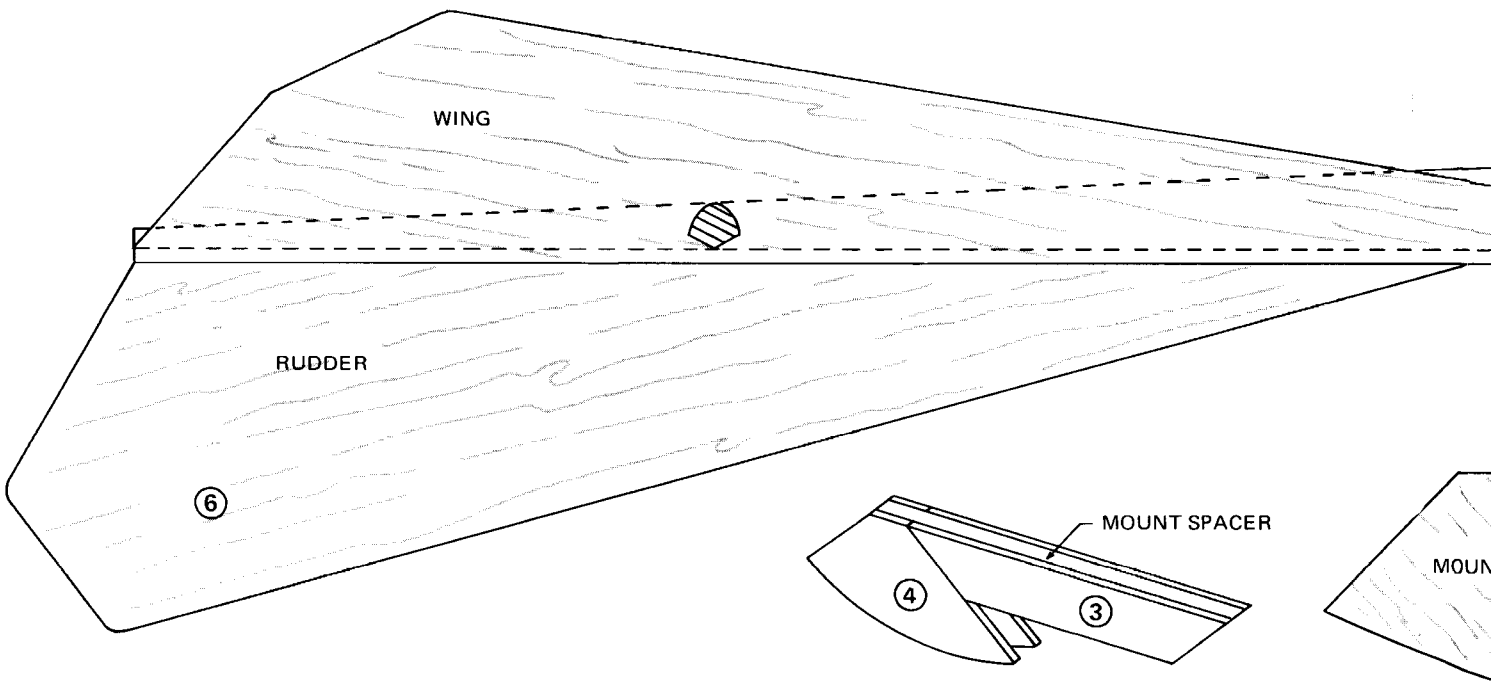
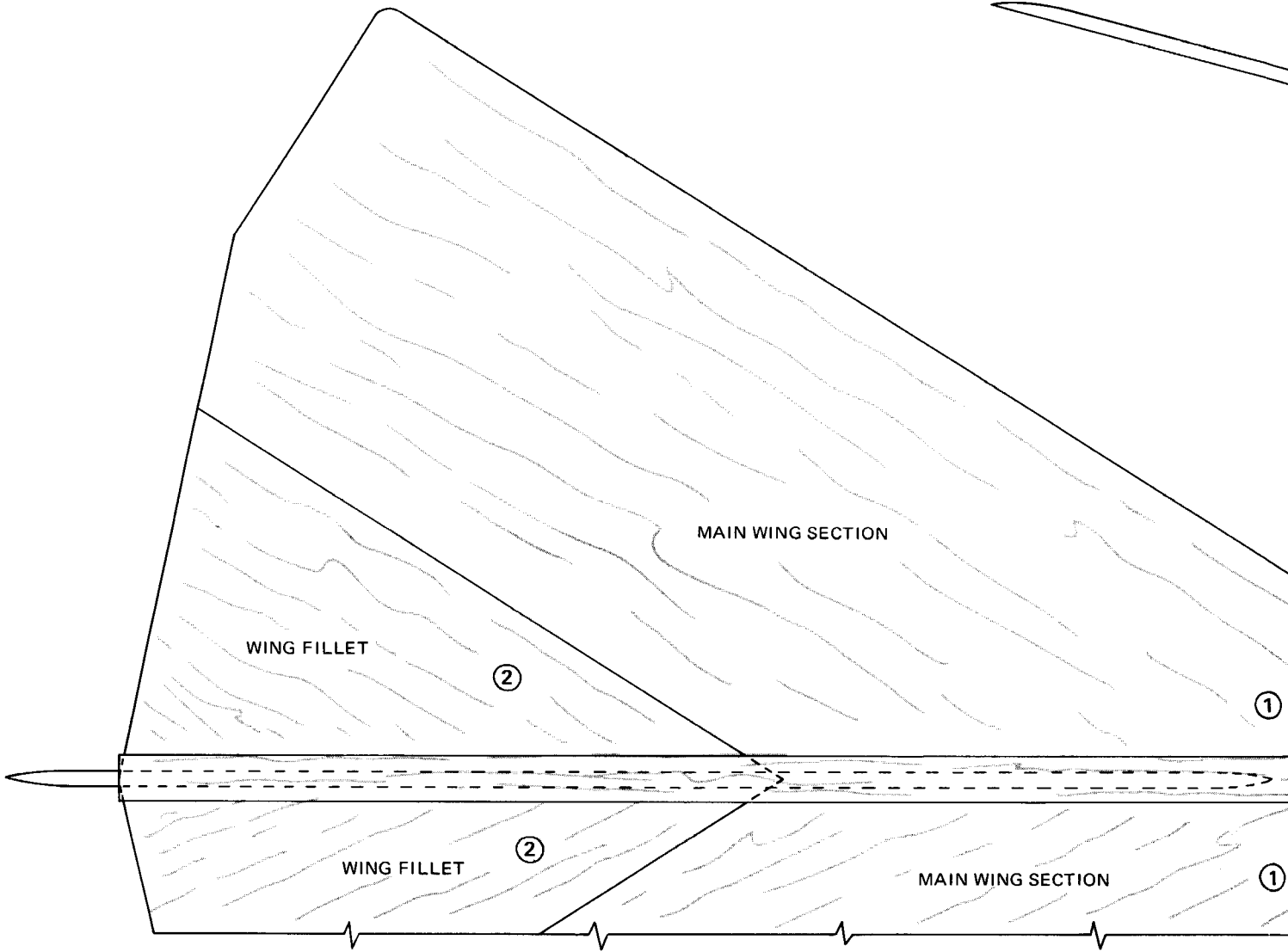

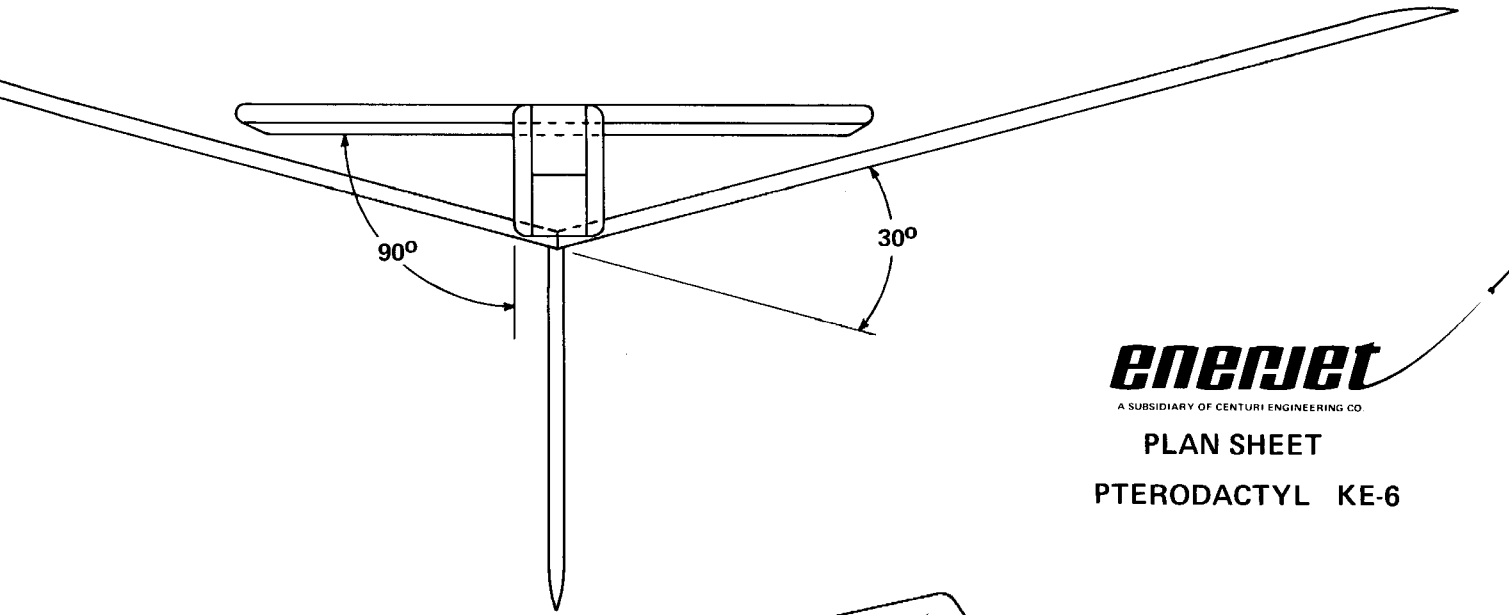

ENERJET

A SUBSIDIARY OF CENTURI ENGINEERING CO.

PLAN SHEET

PTERODACTYL KE-6

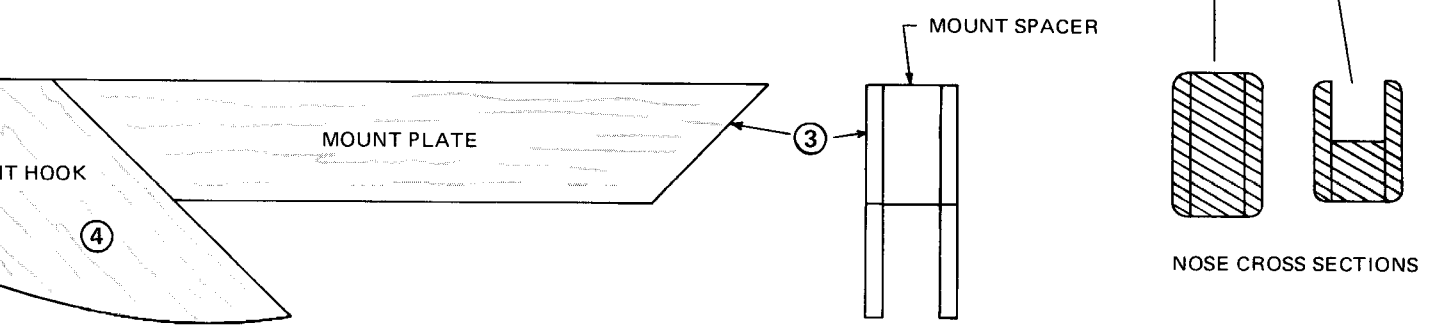
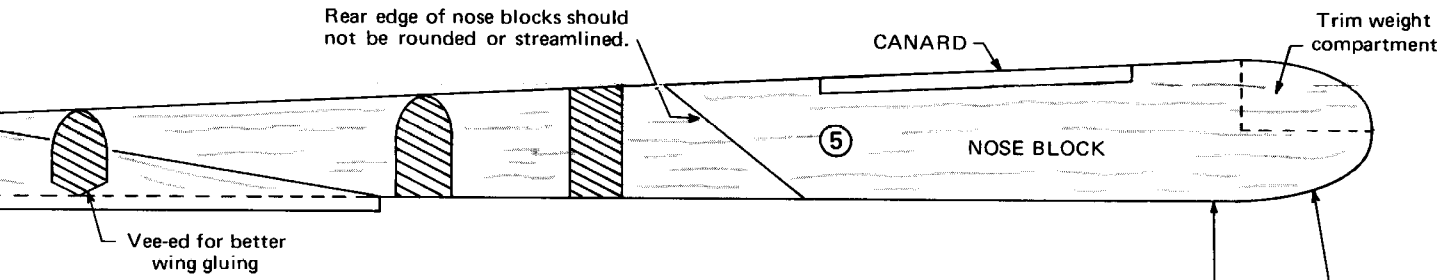
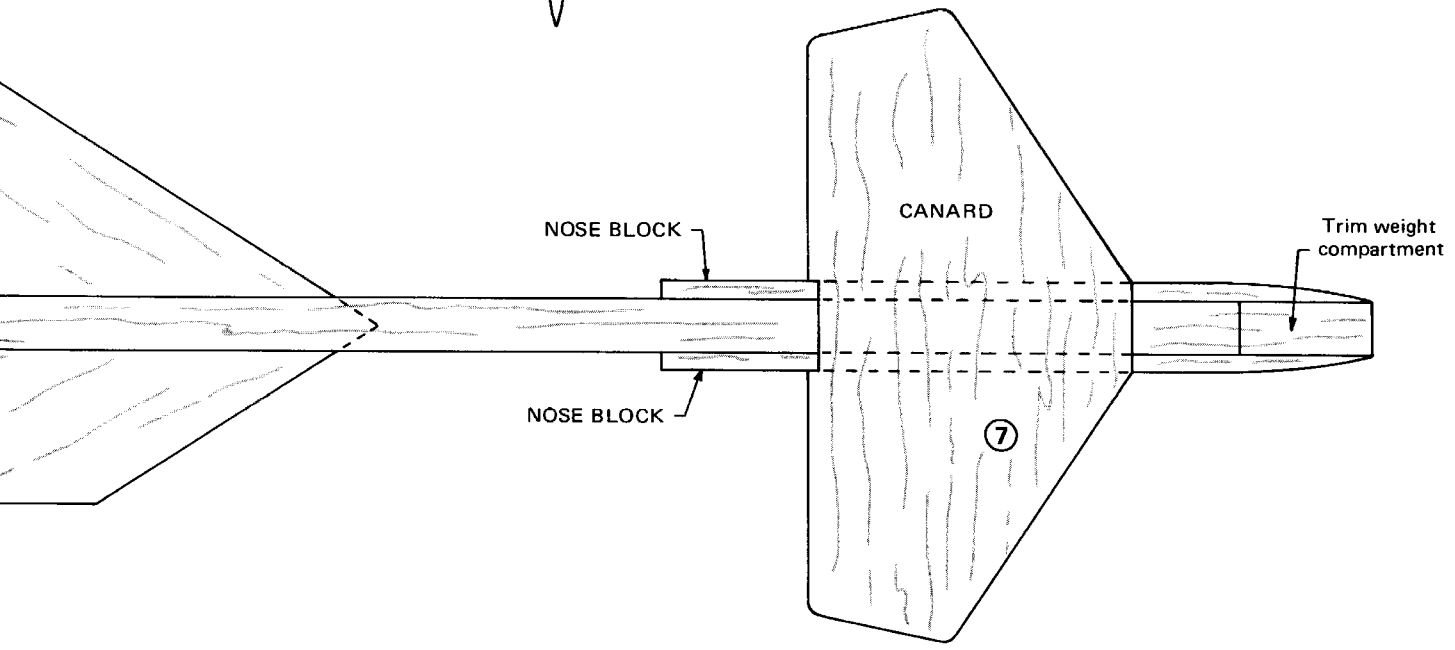

ENERJET

PTERODACTYL KE-6

WING & MOUNT SHEET - IPB-76

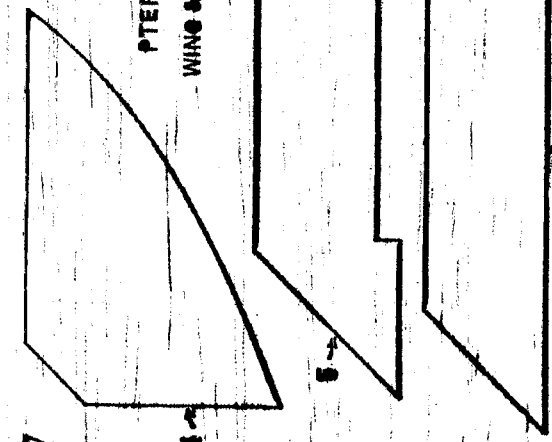

1/8" Balsa

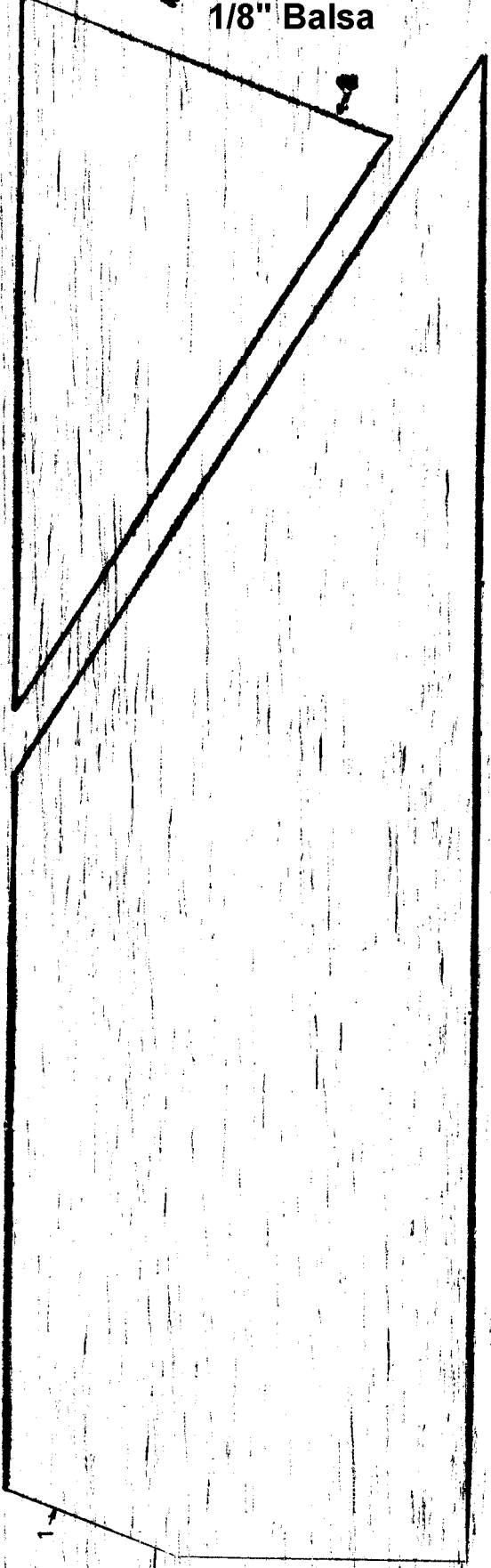

ENERJET

PTERODACTYL KE-6

WING & MOUNT SHEET - IPB-76

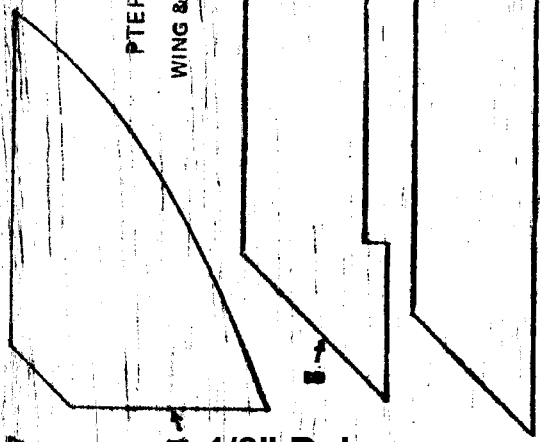

1/8" Balsa

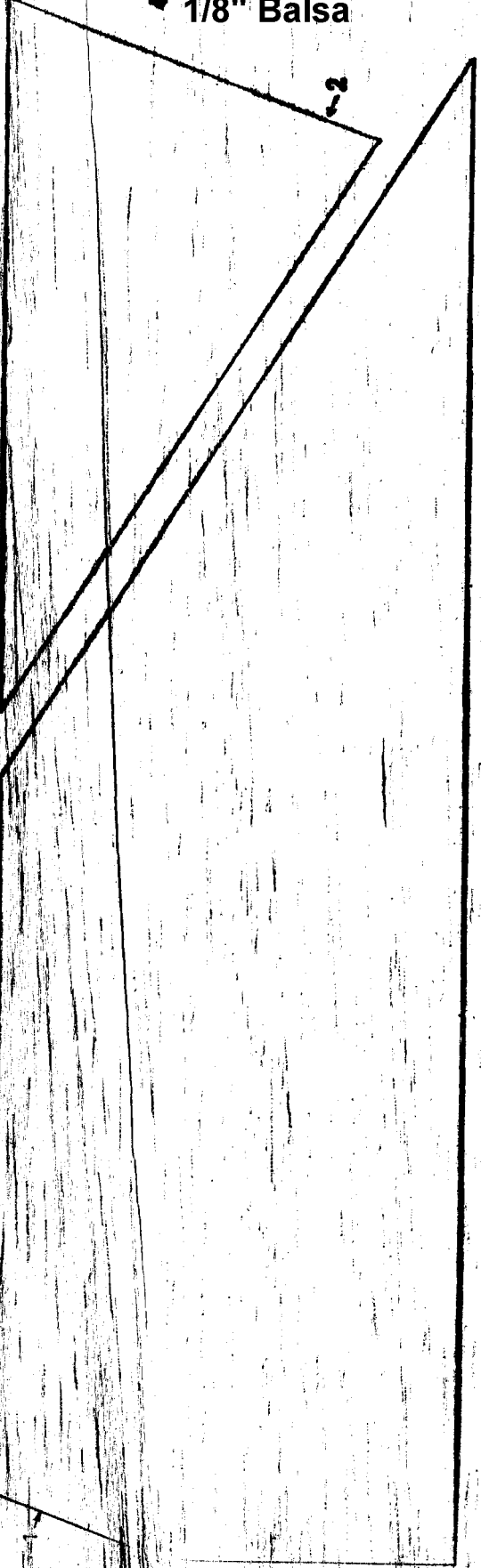

1/8" Basswood

BIGWAVE

PTERODACTYL KIT

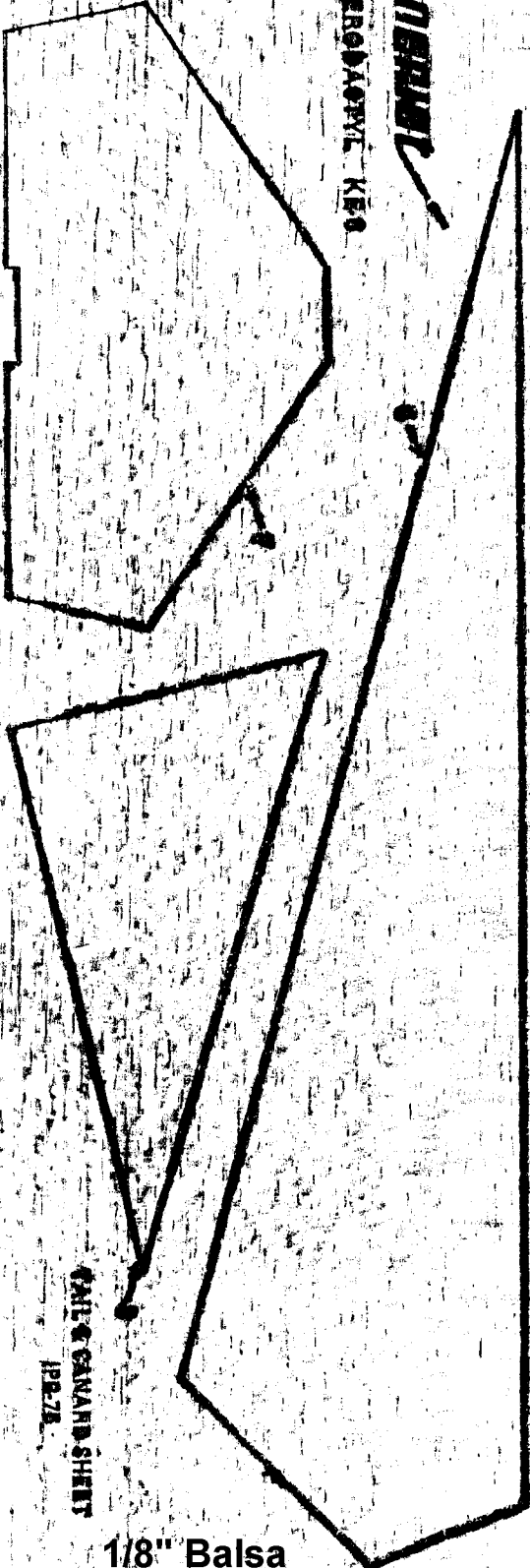

PAUL C. SAVANDB SHRETT
1PR-ZB

1/8" Balsa

PTERODACTYL

PHARLAP

